

Implication of Time Budget Pressure on Organizational Citizenship Behavior And Performance of State Civil Apparatus In The Government of Bangkalan Regency

Ary Suharja¹, Amiartuti Kusumaningtyas², Murgianto³, Sunu Priyawan⁴

¹ Ph.D. Fellow, University of 17 Agustus 1945 Surabaya

² Professor, University of 17 Agustus 1945 Surabaya

^{3,4} Associate Professor, University of 17 Agustus 1945 Surabaya

Corresponding Author: Ary Suharja

ABSTRACT. This study aims to prove and analyze the influence of: Competence of the State Civil Apparatus (SCA), Organizational Commitment, Work Environment and Time Budget Pressure on Work Stress, Organizational Citizenship Behavior (OCB) and SCA Performance in Bangkalan District Government. This research uses survey method. This research was conducted on 4 elements of the Regional Apparatus that represent the Government of Bangkalan Regency: Regional Secretariat, Inspectorate, Regional Planning and Development Agency, and Archive and Library Service. Respondents used as research samples totaled 161 people taken from the Slovin formula. Validity test, reliability test, and hypothesis testing using Structural Equation Modeling (SEM) with AMOS 24 software. The results of the study came to the conclusion: (1) SCA competence has a significant effect on work stress, OCB, and SCA performance, (2) organizational commitment has a significant effect on work stress, OCB, and SCA performance, (3) work environment has a significant effect on work stress, OCB, and SCA performance, (4) time budget pressure significant effect on work stress and performance, (5) work stress has a significant effect on SCA performance, (6) OCB has a significant effect on SCA performance, and (7) time budget pressure does not significantly influence OCB.

KEYWORDS: SCA Competence, Organizational Commitment, Time Budget Pressure, Organizational Citizenship Behavior, SCA Performance.

Date of Submission: 25-02-2020

Date of Acceptance: 11-03-2020

I. INTRODUCTION

In the current era of regional autonomy, local governments are required to hold clean, fair, transparent and accountable government in order to realize good and clean government governance. One approach to realizing good and clean governance is that within the government agency, a civil service must be implemented through an internal supervision function carried out by the Inspectorate of the district / city government on the performance of the State Civil Apparatus (SCA) working in the government environment itself.

The effectiveness of the performance of the SCA in the district / city government is influenced by several factors, namely competency, organizational commitment, and work environment. Goldwasser (1993) explains that the achievement of employee performance can be measured by three indicators namely work quality, quantity of work, and timeliness. The quality of work is measured based on the compatibility of the work results with the applicable standards or rules. Meanwhile, the quantity of work is usually measured based on the suitability of the number of work results with a predetermined target. While the timeliness is measured based on the suitability of the completion of the work with the schedule that has been determined.

The role of the SCA in the regions in implementing national development programs and the management of regional finances has never escaped the spotlight of the community and the central government. Many efforts have been taken by local governments to boost the performance of district / city State Civil Apparatus, including efforts to detect causes and solutions to improve the image of district / city government performance.

The Chairperson of the Performance Team for Optimizing the Performance of the State Civil Apparatus, Waluyo (2019), was quoted in <https://nasional.tempo.co/read/1260597> said the challenge currently faced is that performance appraisal has not been able to photograph the actual performance of the SCA. The same thing was stated by Nugroho (2013) in Pratomo (2016) which explained the main problems faced in the inspectorate in the form of the implementation of coaching and supervisory performance that did not meet the set standards (limited personnel, limited time, and the number of oversight tasks), so that the auditee / unit work is less responsive to the results of the Inspectorate's supervision.

Based on this, the quality of the SCA still needs improvement and strengthening of roles, so that the

level of public trust will be higher and with the expectation of supervision and management of government activities in the regions more transparent and accountable. Within the Bangkalan district government environment there are 9,150 SCA. Based on the report from the Personnel and Regional Apparatus Development Agency of Bangkalan district government in 2018, 545 (5.96%) received good performance scores, and 8.605 (94.04%) scored in the sufficient category.

Based on the background above, the author wishes to conduct research on the effect of competence, organizational commitment, work environment, and time budget pressure on Organizational Citizenship Behavior (OCB) and the performance of the SCA in the Bangkalan district government. Previous research on the factors that influence the performance of the SCA has been carried out, but some research results have shown differences and inconsistencies.

This study aims to examine several factors that can affect the performance of the SCA such as competence, organizational commitment, work environment, and time budget pressure. By testing these factors it is expected to provide an explanation of how these factors affect the performance of the SCA in the Bangkalan district government.

II. LITERATURE REVIEW

Time Budget Pressure. According to Lautania (2011), Time Budget Pressure indicators include: (1) Budget Tightening Level Indicators: (a) Efficiency of time budget that means employees act by minimizing losses or time wastage in carrying out activities. (b) Strict time constraints in the budget that is the employee when making a time budget and must think of time limits in completing work to get the best results. (2) Budget Achievement Indicators: (a) Complete the work on time ie the employee reports the results of the work in accordance with the planned budget, thus forcing the employee to complete the work on time. (b) The level of fulfillment of employee time budget achievement is how much and how many employees meet the target time budget achievement in doing work.

Employee Competency. Spencer and Spencer (Spencer and Spencer, 1993) interpret competency as the underlying characteristics of a person with regard to the effectiveness of individual performance in their work or the basic characteristics of individuals who have causality or as causal links with criteria used as effective references or excellent or superior performance in the workplace or in certain situations. While the components of competence include the following: (1) Motives, which is something that is consistently thought and desired by someone who causes action. (2) Traits, i.e. physical characteristics and consistent responses to various situations or information. (3) Self concept, namely attitudes, values, or self-image of a person (4) Knowledge, i.e. knowledge or information possessed by someone in a specific specific field (5) Skill, namely the ability to do or carry out certain physical tasks or certain mental tasks.

Organizational Commitment. According to Robbins (2008) there are three dimensions of organizational commitment, namely: (1) Affective Commitment, namely emotional feelings for the organization and beliefs in its values, (2) Normative Commitment, which is the feeling of being obliged to remain in the organization because it must be so, the action is the right thing to do, and (3) Sustainable Commitment is the economic value that is felt from surviving in an organization when compared to leaving the organization.

Work Environment. According Sedarmayati (2009: 21), states that the work environment is all the tools and materials faced, the environment around which the worker works, the method of work, and work arrangements whether he is doing it individually or in groups. Broadly speaking, the type of work environment is divided into two factors, namely: (1) Physical Work Environment Factors consisting of: Coloring, Lighting, Air, Noise, Motion Space, Safety and Cleanliness and (2) Non-Physical Work Environment Factors consisting of: Work structure, work responsibilities, attention and support of leaders, cooperation between groups and smooth communication.

Job Stress. According to Robbins (2008) stress is a dynamic condition in which an individual is confronted with an opportunity, obstacle, or demand that is associated with what is very desirable and the results are perceived as uncertain and important. According to Robbins (2008) there are 2 factors that can cause stress, namely: (1) Organizational factors include task demands, role demands and interpersonal demands and (2) Personal factors include family problems, economic problems, and personality.

Organizational Citizenship Behavior (OCB). Be free in the sense that the behavior is not a requirement that must be carried out in a particular role or certain job description, or behavior that is a personal choice (Podsakoff et al. 2000).

Employee Performance. Performance is a function of the interaction between ability (Ability = A), motivation (motivation = M) and opportunity (Opportunity = O) or Performance = $f(A \times M \times O)$; meaning: performance is a function of ability, motivation and opportunity (Robbins, 1996).

Based on the above theoretical explanation, a Conceptual Framework can be drawn up on the relationship of the variables of Competency, Organizational Commitment, Work Environment, and Time Budget Pressure on Work Stress, Organizational Citizenship Behavior (OCB) and State Civil Service

Performance. The conceptual framework is illustrated in Figure 1.

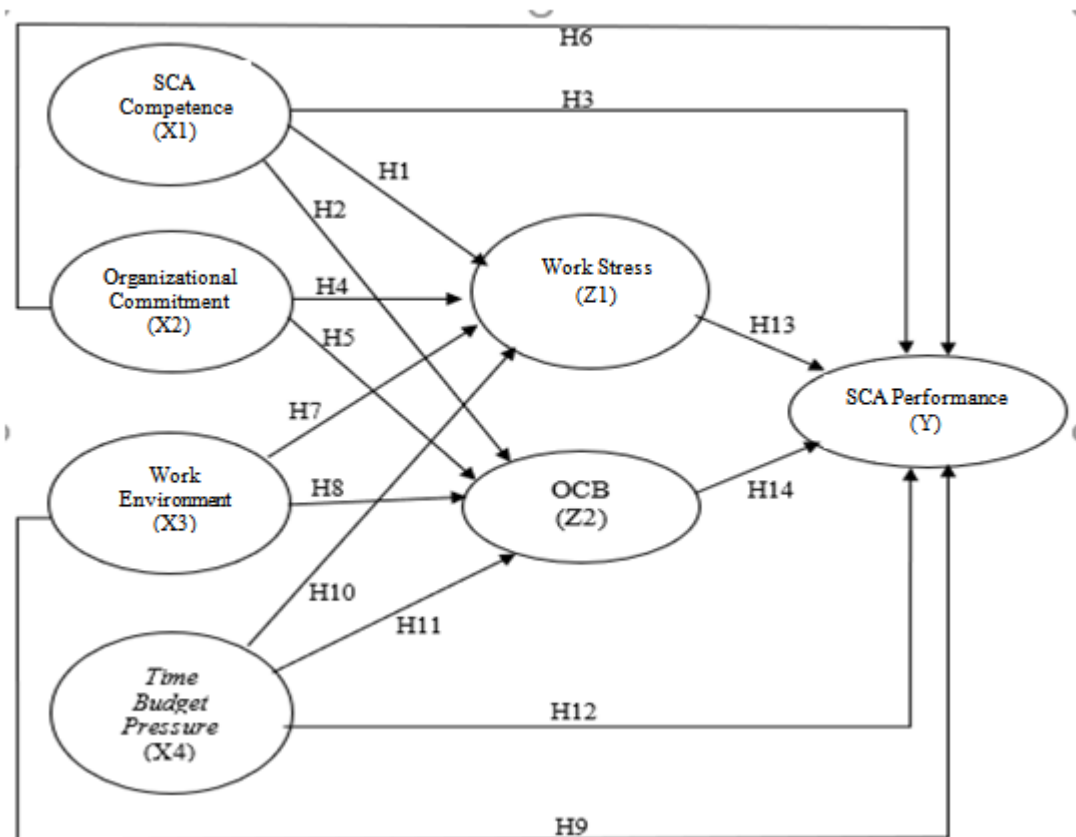

Figure 1. Research Conceptual Framework

Based on the formulation of the problem, literature review and conceptual framework, proposed 14 research hypotheses as follows:

- H-01 Time budget pressure has a significant effect on work stress in the Bangkalan Regency Government.
- H-02 Time budget pressure has a significant effect on Organizational Citizenship Behavior in Bangkalan District Government.
- H-03 Time budget pressure has a significant effect on the performance of the State Civil Apparatus in the Bangkalan Regency Government.
- H-04 SCA Competency has a significant effect on work stress in the Bangkalan Regency Government.
- H-05 SCA Competency has a significant effect on Organizational Citizenship Behavior within the Bangkalan District Government.
- H-06 SCA Competency has a significant effect on the performance of SCA in the Bangkalan Regency Government.
- H-07 Organizational Commitment has a significant effect on work stress in the Bangkalan Regency Government.
- H-08 Organizational Commitment has a significant effect on Organizational Citizenship Behavior within the Bangkalan District Government.
- H-09 Organizational Commitment has a significant effect on the performance of SCA in the Bangkalan District Government.
- H-10 The work environment has a significant effect on work stress in the Bangkalan Regency Government.
- H-11 The work environment has a significant effect on Organizational Citizenship Behavior (OCB) in the Bangkalan District Government.
- H-12 The work environment has a significant effect on the performance of the State Civil Apparatus in the Bangkalan Regency Government.
- H-13 Work stress has a significant effect on the performance of the State Civil Apparatus in the Bangkalan Regency Government.
- H-14 Organizational Citizenship Behavior significantly influences the performance of SCA in the Bangkalan District Government.

III. RESEARCH METHODOLOGY

Population and Sample. The study was conducted at the Bangkalan Regency Government office. The population in this study is the State Civil Apparatus in the Bangkalan District Government. Retrieval of population is carried out at SCA in the area of the Regional Secretariat, Inspectorate, BAPPEDA, Archive and Library Office. This agency represented all elements in the Bangkalan District Government, namely representatives from the Secretariat, Inspectorate, Agency and Service with a total population of 345 SCA. According to Emory (2005: 87) for descriptive methods a minimum sample of 10% of the population and for a relatively small population an acceptable sample of at least 20% of the population. Of the several methods available, for the sample selection proposed by the experts, in this study drawing samples using the proportional random sampling method (proportional sampling technique). The number of sample members is determined by the Slovin formula: $n = N / (1 + N \cdot e)$ based on the above calculation, there were 161 samples. Data collection using questionnaires, observation and interviews.

Method of Collecting Data. Data retrieval in this study was carried out through personality administered questionnaires to enable researchers to interact directly and provide explanations as needed to the respondents. The Likert scale is used to measure the attitudes, opinions and perceptions of a respondent about the phenomena experienced by the government agency where he / she is assigned. Time Budget Pressure indicators include: Budget Tightening Level Indicators and Budget Achievement. State Civil Service Competency indicators include: Motives, Traits, Self concepts, Knowledge. Organizational Commitment indicators include: Affective Commitment, Normative Commitment, and Sustainable Commitment. Work environment indicators include: Physical Work Environment and Non-Physical Work Environment. Work Stress indicators include: Organizational factors and Personal factors. Organizational Citizenship Behavior (OCB) indicators include: Altruism, Civic virtue, Conscientiousness, Courtesy, Sportmanship. State Civil Service Performance indicators include: quality, quantity, timeliness, effectiveness, independence.

Data Analysis Method. Data analysis in this study uses an analytical method that can provide a simultaneous analysis process associated with a multi-variant research model as in this study, namely Structural Equation Modeling (SEM) analysis.

IV. RESULTS AND DISCUSSION

Validity Test

Validity test is carried out based on the dimensions of each variable. In Table 1.1 and Table 1.2, the validity test results of each indicator that form the research variables are presented. In the table it appears that the value of the matrix component for each indicator > 0.50 so that it shows that all instruments used in the study are valid.

Table 1.1 Test Validity of Independent Variables

Indicators	Item	Pearson Correlation	Sig.	Terms	Information
1. Time Budget Pressure Variable					
Budget Tightening	X4.1.1	0,782	0,000	Sig. \leq 5%	Valid
	X4.1.2	0,833	0,000	Sig. \leq 5%	Valid
Budget Achievement	X4.2.1	0,893	0,000	Sig. \leq 5%	Valid
	X4.2.2	0,811	0,000	Sig. \leq 5%	Valid
2. SCA Competence Variable					
X1.1 Motives	X1.1.1	0,604	0,000	Sig. \leq 5%	Valid
	X1.1.2	0,652	0,000	Sig. \leq 5%	Valid
X1.2 Traits	X1.2.1	0,640	0,000	Sig. \leq 5%	Valid
	X1.2.2	0,544	0,002	Sig. \leq 5%	Valid
X1.3 Self concept	X1.3.1	0,550	0,002	Sig. \leq 5%	Valid
	X1.3.2	0,620	0,000	Sig. \leq 5%	Valid
X1.4 Knowledge	X1.4.1	0,642	0,000	Sig. \leq 5%	Valid
	X1.4.2	0,557	0,001	Sig. \leq 5%	Valid
X1.5 Skills	X1.5.1	0,519	0,003	Sig. \leq 5%	Valid
	X1.5.2	0,510	0,004	Sig. \leq 5%	Valid
3. Organizational Commitment Variable					
X2.1 Affective Commitment	X2.1.1	0,574	0,001	Sig. \leq 5%	Valid
	X2.1.2	0,747	0,000	Sig. \leq 5%	Valid
X2.2 Normative Commitment	X2.2.1	0,752	0,000	Sig. \leq 5%	Valid
	X2.2.2	0,731	0,000	Sig. \leq 5%	Valid
X2.3 Sustainable Commitment	X2.3.1	0,715	0,000	Sig. \leq 5%	Valid
4. Work Environment Variable					
X3.1 Physical Work Environment	X3.1.1	0,589	0,001	Sig. \leq 5%	Valid
	X3.1.2	0,732	0,000	Sig. \leq 5%	Valid
	X3.1.3	0,634	0,000	Sig. \leq 5%	Valid
	X3.1.4	0,579	0,001	Sig. \leq 5%	Valid
X3.2 Non-Physical Work Environment	X3.2.1	0,740	0,000	Sig. \leq 5%	Valid

Indicators	Item	Pearson Correlation	Sig.	Terms	Information
1. Time Budget Pressure Variable					
Budget Tightening	X4.1.1	0,782	0,000	Sig. ≤ 5%	Valid
	X4.1.2	0,833	0,000	Sig. ≤ 5%	Valid
Budget Achievement	X4.2.1	0,893	0,000	Sig. ≤ 5%	Valid
	X4.2.2	0,811	0,000	Sig. ≤ 5%	Valid
	X3.2.2	0,549	0,002	Sig. ≤ 5%	Valid
	X3.2.3	0,732	0,000	Sig. ≤ 5%	Valid
	X3.2.4	0,710	0,000	Sig. ≤ 5%	Valid

Table 1.2 Test Validity of Intervening and Dependent Variables

Indicators	Item	Pearson Correlation	Sig.	Terms	Information	
5. Work Stress Variable						
Z1.1	Organizational factors	Z1.1.1	0,840	0,000	Sig. ≤ 5%	Valid
		Z1.1.2	0,631	0,000	Sig. ≤ 5%	Valid
Z1.2	Personal factors	Z1.2.1	0,739	0,000	Sig. ≤ 5%	Valid
		Z1.2.2	0,587	0,001	Sig. ≤ 5%	Valid
6. OCB Variable						
Z2.1	Altruism	Z2.1.1	0,727	0,000	Sig. ≤ 5%	Valid
		Z2.1.2	0,561	0,001	Sig. ≤ 5%	Valid
Z2.2	Civic virtue	Z2.2.1	0,572	0,001	Sig. ≤ 5%	Valid
		Z2.2.2	0,648	0,000	Sig. ≤ 5%	Valid
Z2.3	Conscientiousness	Z2.3.1	0,642	0,000	Sig. ≤ 5%	Valid
		Z2.3.2	0,658	0,000	Sig. ≤ 5%	Valid
Z2.4	Courtesy	Z2.4.1	0,617	0,000	Sig. ≤ 5%	Valid
		Z2.4.2	0,753	0,000	Sig. ≤ 5%	Valid
Z2.5	Sportmanship	Z2.5.1	0,621	0,000	Sig. ≤ 5%	Valid
		Z2.5.2	0,765	0,000	Sig. ≤ 5%	Valid
7. SCA Performance Variable						
Y.1	Quality	Y.1.1	0,759	0,000	Sig. ≤ 5%	Valid
Y.2	Quantity	Y.2.1	0,847	0,000	Sig. ≤ 5%	Valid
Y.3	Timeliness	Y.3.1	0,756	0,000	Sig. ≤ 5%	Valid
Y.4	Effectiveness	Y.4.1	0,726	0,000	Sig. ≤ 5%	Valid
Y.5	Independence	Y.5.1	0,781	0,000	Sig. ≤ 5%	Valid

Reliability Test

The reliability test results for all variables are illustrated from the Cronbach Alpha value above 0.60 which means that all research variables are reliable.

Table 2. Research Variability Test Reliability

Variable	Cronbach's Alpha	Critical Value	Information
SCA Competency (X1)	0,779	≥ 0,60	Reliable
Organizational Commitment (X2)	0,764	≥ 0,60	Reliable
Work Environment (X3)	0,869	≥ 0,60	Reliable
Time Budget Pressure (X4)	0,842	≥ 0,60	Reliable
Work Stress (Z1)	0,660	≥ 0,60	Reliable
OCB (Z2)	0,852	≥ 0,60	Reliable
SCA Performance (Y)	0,826	≥ 0,60	Reliable

Description of Research Variables

All variables indicate the average score in the range 3.4 - 4.2 (agree / high) as shown in Table 3.

Table 3. Variable Descriptive Statistics

Variable		Mean	Category
X.1	SCA Competency	4,10	High
X.2	Organizational Commitment	4,07	High
X.3	Work Environment	4,02	High
X.4	Time Budget Pressure	4,06	High
Z1	Work Stress	3,97	High
Z.2	OCB	4,01	High
Y.1	SCA Performance	4,12	High

Analysis of Measurement Model

The measurement model process is a process of the CFA test that is confirmatory factor analysis. CFA serves to identify whether indicators are constructs of research variables or in other words these indicators are one entity or have undimensionality. CFA tests were performed on each exogenous construct and endogenous construct. CFA test is conducted to test the validity and reliability of indicators as constructors.

In this study, the CFA test will be analyzed using AMOS 24.0 software which is performed on each exogenous construct and endogenous construct, which consists of several variables, namely competency, organizational commitment, work environment, time budget pressure, work stress, organizational citizenship behavior, and SCA performance. CFA test results on exogenous constructs consisting of competency, organizational commitment, work environment, and time budget pressure variables using AMOS 24 software are as follows:

Table 4. Validity and Reliability of Exogenous Construct

Variable	Indicators	Factor Loading (FL)	(FL) ²	Error (1-FL ²)	Construct Reliability (CR)
SCA Competency (X1)	X1.1	0,561	0,315	0,685	0,784
	X1.2	0,629	0,396	0,604	
	X1.3	0,709	0,503	0,497	
	X1.4	0,697	0,486	0,514	
	X1.5	0,643	0,413	0,587	
Organizational Commitment (X2)	X2.1	0,766	0,587	0,413	0,780
	X2.2	0,717	0,514	0,486	
	X2.3	0,725	0,526	0,474	
Work Environment (X3)	X3.1	0,988	0,976	0,024	0,881
	X3.2	0,777	0,604	0,396	
Time Budget Pressure (X4)	X4.1	0,795	0,632	0,368	0,716
	X4.2	0,696	0,484	0,516	

CFA test results on endogenous constructs consisting of variables of work stress, organizational citizenship behavior, and SCA performance using AMOS 24 software are as follows:

Table 5. Validity and Reliability of Endogenous Constructs

Variable	Indicators	Factor Loading (FL)	(FL) ²	Error (1-FL ²)	Construct Reliability (CR)
Work Stress (Z1)	Z1.1	0,712	0,507	0,493	0,707
	Z1.2	0,767	0,588	0,412	
Organizational Citizenship Behavior (Z2)	Z2.1	0,773	0,598	0,402	0,851
	Z2.2	0,666	0,444	0,556	
	Z2.3	0,703	0,494	0,506	

	Z2.4	0,754	0,569	0,431	
	Z2.5	0,749	0,561	0,439	
SCA Performance (Y)	Y.1	0,686	0,471	0,529	0,848
	Y.2	0,724	0,524	0,476	
	Y.3	0,770	0,593	0,407	
	Y.4	0,739	0,546	0,454	
	Y.5	0,710	0,504	0,496	

Table 5 shows that all indicators on endogenous constructs consisting of work stress variables, organizational citizenship behavior, and SCA performance have factor loading values greater than 0.50 so that these indicators are valid in constructing constructs and can be used to build models. The table also shows that measurements of endogenous constructs consisting of work stress variables, organizational citizenship behavior, and SCA performance produce construct reliability values of 0.707; 0.851; and 0.848 (all greater than 0.70), so it was concluded that endogenous constructs consisting of work stress variables, organizational citizenship behavior, and SCA performance were reliable in developing models developed in this study.

Structural Equation Modeling (SEM) Analysis

The next step is to test the hypothesis using the CR value and its probability. The parameter of the presence or absence of partial effect can be determined based on the value of CR (Critical Ratio). To determine whether there is an influence of exogenous variables on endogenous variables and endogenous variables on endogenous variables, the provisions are used if the calculated CR value ≥ 1.96 or a significance value ≤ 0.05 , then it is decided that there is a significant influence between these variables.

Following are the results of hypothesis testing based on the value of standardized regression weight in the structural equation model after modification:

Table 6. Hypothesis Testing Through Regression Weight Test

Hyp.	Causality Relations	Coef.	C.R.	P-value	Information
H ₁	Time Budget Pressure (X4) → Stres Kerja (Z1)	-0,274	-2,390	0,017	Sig.
H ₂	Time Budget Pressure (X4) → OCB (Z2)	0,094	0,885	0,376	Not Sig.
H ₃	Time Budget Pressure (X4) → SCA Performance (Y)	0,246	2,590	0,010	Sig.
H ₄	SCA Competency (X1) → Work Stress (Z1)	-0,243	-2,286	0,022	Sig.
H ₅	SCA Competency (X1) → OCB (Z2)	0,318	3,066	0,002	Sig.
H ₆	SCA Competency (X1) → SCA Performance (Y)	0,230	2,388	0,017	Sig.
H ₇	Organizational Commitment (X2) → Work Stress (Z1)	-0,267	-2,641	0,008	Sig.
H ₈	Organizational Commitment (X2) → OCB (Z2)	0,192	2,052	0,040	Sig.
H ₉	Organizational Commitment (X2) → SCA Performance (Y)	0,272	2,951	0,003	Sig.
H ₁₀	Work Environment (X3) → Work Stress (Z1)	-0,336	-2,859	0,004	Sig.
H ₁₁	Work Environment (X3) → OCB (Z2)	0,269	3,046	0,002	Sig.
H ₁₂	Work Environment (X3) → SCA Performance (Y)	0,082	0,884	0,377	Not Sig.
H ₁₃	Work Stress (Z1) → SCA Performance (Y)	-0,262	-2,071	0,038	Sig.
H ₁₄	OCB (Z2) → SCA Performance (Y)	0,183	2,019	0,043	Sig.

V. CONCLUSIONS AND RECOMMENDATIONS

Based on the formulation of the problem, and the results of research and discussion, the conclusions of this study are: (1) SCA competence has a significant effect on work stress, Organizational Citizenship Behavior, and SCA performance, (2) organizational commitment has a significant effect on work stress, Organizational Citizenship Behavior, and SCA performance, (3) work environment has a significant effect on work stress, Organizational Citizenship Behavior, and SCA performance, (4) time budget pressure significant effect on work stress and performance, (5) work stress has a significant effect on SCA performance, (6) Organizational Citizenship Behavior has a significant effect on SCA performance, and (7) time budget pressure does not significantly influence Organizational Citizenship Behavior.

Referring to the conclusions above, the authors provide suggestions: (1) In this study found that work environment variables did not significantly influence SCA performance and Time Budget Pressure had no significant effect on Organizational Citizenship Behavior. For further research can examine in depth about the influence of the work environment on SCA Performance and the influence of Time Budget Pressure on Organizational Citizenship Behavior, (2) Research on the relationship between time budget pressure and work stress is rarely conducted by researchers, so in subsequent studies it is necessary done about this relationship, (3) To improve the performance of SCA in Bangkalan Regency Government can be done by increasing the variables that affect SCA performance, namely: competence, organizational commitment, Time Budget Pressure, work stress, and Organizational Citizenship Behavior.

BIBLIOGRAPHY

- [1]. Busro, Muhammad. 2018. Theories of Human Resource Management. Jakarta: Prenadimedia.
- [2]. Eko, Sasono. 2004. Managing Work Stress. Journal of Economic Focus. Vol III. No.2 pp. 48-56.
- [3]. Hutapea, Parlian and Marianna Thoha. 2008. Competency Plus. Jakarta. PT. Gramedia Main Library.
- [4]. Mahmudi. (2012). Public Sector Performance Management, Edition 3. Yogyakarta: UPP STIM YKPN.
- [5]. Mangkunegara, A. A. Prabu. 2005. Human Resources Performance Evaluation. Bandung: Refika.
- [6]. Miner, John B. 1990. Organizational Behavior: Performance and Productivity, New York: Random House.
- [7]. Pratomo, Dony. 2016. Journal of Accounting and Business. Vol. 16, No. 2, Agustus 2016: 123 – 133.
- [8]. Robbins, Stephen P. 2006. Organizational Behavior. Tenth edition, Jakarta: PT Index.
- [9]. Sopiah. 2008. Organizational Behavior, Yogyakarta: Andi Offset.
- [10]. Sugiyono. 2003. Business Research Methods, Bandung: CV. Alfabeta.
- [11]. Suhardi and Syaifullah (2017), Influence of Motivation, Competence, Work Environment, Compensation for Organizational Citizenship Behavior and Employee Life Insurance Performance in Riau Islands Province
- [12]. Suryanto, 2002, Organizational Commitment: Perspective of Social psychology (Proceedings of APIO Scientific Meeting I, 2-3 August 2003, pp. 148-155).
- [13]. Susanto. 1997. Corporate Culture, Management and Business Competition, Jakarta: PT. Elex Media Komputindo.
- [14]. Veithzal, Rivai. 2005. Human Resource Management for Companies from Theory to Practice, Jakarta: PT. Rajagrafindo Persada.

Ary Suharja " Implication of Time Budget Pressure on Organizational Citizenship Behavior And Performance of State Civil Apparatus In The Government of Bangkalan Regency" *International Journal of Business and Management Invention (IJBMI)*, vol. 09(02), 2020, pp 45-52.